

## Specifications

## Water-Cooled

<b>Instrumentation</b>	Front display high pressure gauge Front display low pressure gauge Front display hour meter
<b>Interlock Functions</b>	Compressor over! temperature sensor Helium under! pressure sensor
<b>Status Lights:</b>	Front display POWER ON Front display RUN Front display OVERTEMPERATURE
<b>Compressor</b>	Scroll type for Helium service Sealed motor Oil lubricated and cooled
<b>Operating Noise Level</b>	62-65 db at 10 ft.
<b>Power Switching</b>	Integral magnetic contactor
<b>Electrical Access</b>	Top Panel
<b>Coolant</b>	Water 1.5 gpm at 77°F
<b>Weight</b>	275 lbs.
<b>Dimensions</b>	26" H x 19" W x 24" D
<b>Casters</b>	Included



### Services

Helium gas charge/vent valve with ½" Aeroquip fitting  
Oil charge/drain valve with ¼" Aeroquip  
Module interconnections with VCO O-ring face-seal fittings  
Removable panels (sides, top, front)  
Top electrical access panel

### Electrical Power Requirement

5.5 kW, 208/240 V, 3 phase, 50/60 Hz, 16 amps  
5.5 kW, 440/480 V, 3 phase, 50/60 Hz, 8 amps

### Heat Exchange

5.5 kW, 208/240 V, 3 phase, 50/60 Hz, 16 amps  
5.5 kW, 440/480 V, 3 phase, 50/60 Hz, 8 amps

### Remote Operation

208V1 phase standard  
110V1 phase optional  
24V DC optional

Static Helium Pressure	Ambient Temperature Operating Range	Ambient Storage Temperature
210 ± 5 psig at 70°F (21°C)	50°F to 100°F (10°C to 38°C)	Above 40°F (4.44°C)

<b>Coolant in</b>	1/4" NPT MALE
<b>Coolant out</b>	1/4" NPT MALE
<b>Main power cable</b>	10 ft. (3m) pigtail
<b>Remote start/stop connector</b>	8 pin twist lock
<b>Expander power connector</b>	4 pin twist lock
<b>Helium out</b>	½" Aeroquip self-sealing fitting
<b>Helium in</b>	½" Aeroquip self-sealing fitting

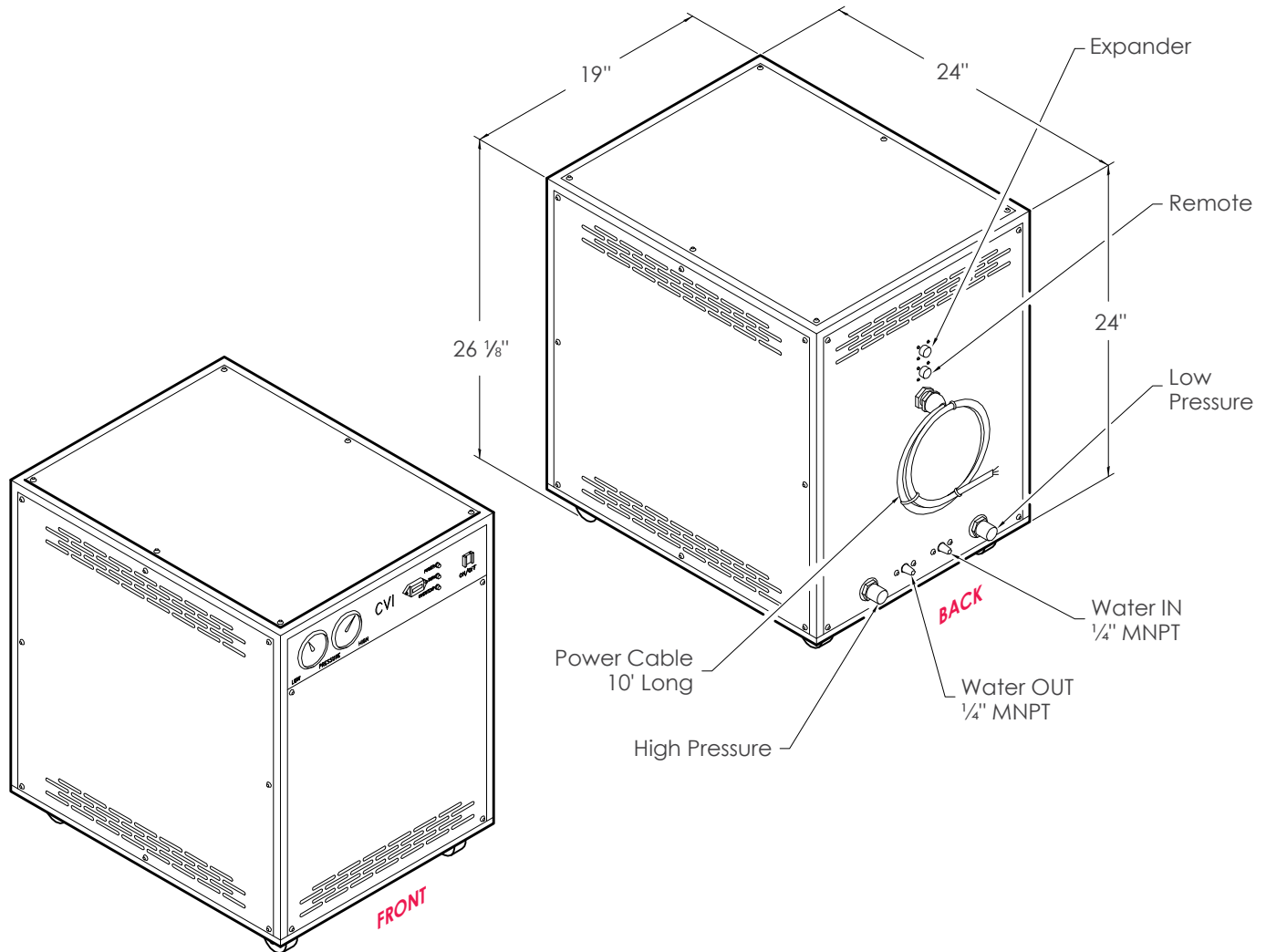

## CBST 6.0 Water-Cooled Scroll Compressor